

Piezo Ultrasonic Motors

PZM-70L-xxx Series

Motor Manual

V2.0 2020/04



For information on the availability of products, please contact our sales.
Subject to technical modifications without notice.
All details provided are technical data which do not constitute warranted qualities.

Important: Please retain this information for future reference.

Warnings

Please strictly keep control of specified voltage and capacity of the motor and load range. Any external power supply used with the piezo motors shall comply with relevant regulations and standards applicable in the country of intended use.

The connection of incompatible devices to the connector may affect compliance or result in damage to the unit and invalidate the warranty.

All peripherals used with the piezo motors should comply with relevant standards for the country of use and be marked accordingly to ensure that safety and performance requirements are met.

Instructions for safe use

To avoid malfunction or damage to your piezo motors please observe the following:

- Do not touch the rod (shaft) of piezo motors, which is lubricated.
- Do not store or operate the motor in the atmosphere or material where erosive gases are present (e.g. H₂S, SO₂, NO₂ and Cl₂, etc.)
- Do not expose it to water, moisture or place on a conductive surface whilst in operation.
- Do not set the motor near exothermic parts such as transformers. The ambient temperature might have influence on the motor.
- Do not operate the motor in over-load condition. In case of indicated polarity of the motor, please do not run with opposite polarity. This may cause undesirable damage or change of characteristics of the motor.
- Take care while handling (e.g. use rubber/latex fingerstall/ gloves) to avoid mechanical or electrical damage to the motor.
- Do not give shock to the piezo motors.
- Do not hold the end of wire (or FPCB) to handle the motor. This may change the characteristics of the motor or cause undesired damage.
- Avoid handling the ceramic discs or cable **while it is powered**, to minimize the risk of electrostatic discharge damage.
- Do not set-up piezo motors on a conductive surface.

※ We strongly recommend in the Set-up of the motor to hold the rod(shaft) with a soft material such as a rubber cap (reference: Figure 4-1).

Table of Contents

1. General Information
2. Characteristics of PZM-70L-xxxx Series
 - 2.1 Mechanical characteristics
 - 2.2 Electrical characteristics
3. Drawing of PZM-70L-xxx
4. Application Information
 - 4.1 Driving waveform
 - 4.2 Mechanical characteristics
 - 4.3 Position sensors
 - 4.4 Mobile part/slider examples
5. Driving Circuit
 - 5.1 Single IC solution 1
 - 5.2 Single IC solution 2
 - 5.3 DC-DC converter
6. Evaluation Kit (PMC1202/ PMC1804)
7. Reliability test result

1. General Information

- 1.1 This manual defines the standard specifications of PZM-70L-xxx series.
- 1.2 PZM-70L-xxx (xxx is rod/shaft length) has a range of standard rod lengths. Within certain ranges the length can be customized.
- 1.3 Characteristics of electrical noise, mechanical noise, clearance noise, vibration, service life etc. vary on mounting situation.
- 1.4 Discrepancy from manual specifications needs mutual proof.
- 1.5 Modifications for optimized performance can be mutually evaluated.
- 1.6 Damages by using the motor out of specification will invalidate the warranty.
- 1.7 When safety standards or certificates are required please contact us.
- 1.8 We always try to further optimize our manuals. We welcome your suggestions and corrections.

2. Characteristics of the PZM-70L-xxx Series

2.1 mechanical characteristics

Item	Unit	Value *	Condition
Speed (no load)	mm/s	>15	Driving voltage: 25V
Max-thrust	g.f	>50	Frequency: 45 ~ 55 kHz
Holding-force	g.f	140 ~160	Temperature: ~25°C
Stroke	mm	<15	
Rod(shaft) length	mm	<30	

* The speed and thrust of PZM-70L-xxx depends on the mobile part (slider) type, rod holder (e.g. rubber cap) type, length of rod and especially, the driving voltage.

2.2 Electrical characteristics

Item	Unit	Value *	Condition
Driving frequency	kHz	45~55	Piezo-Motor-Meter
Driving voltage	V	20 ~35	
Power Consumption	mW	<500	

*There is small variance of the driving frequency based on the mobile part (slider) type, rod holder (e.g. rubber cap) type and length of rod.

*The power-consumption depends on the driving voltage. Optimization can be needed based on individual application.

3. Drawing of PZM-70L-xxx

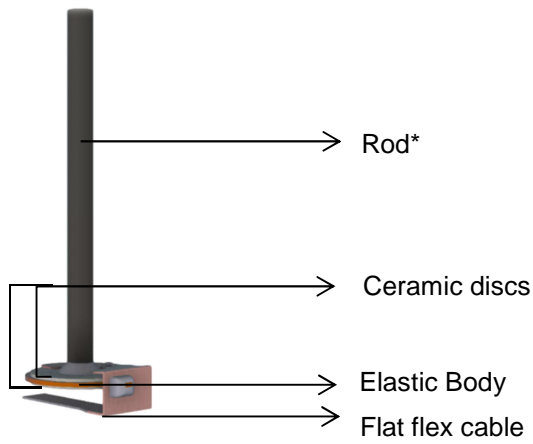

*The rod length can be changed on demand. Standard length range is specified in mechanical characteristics.

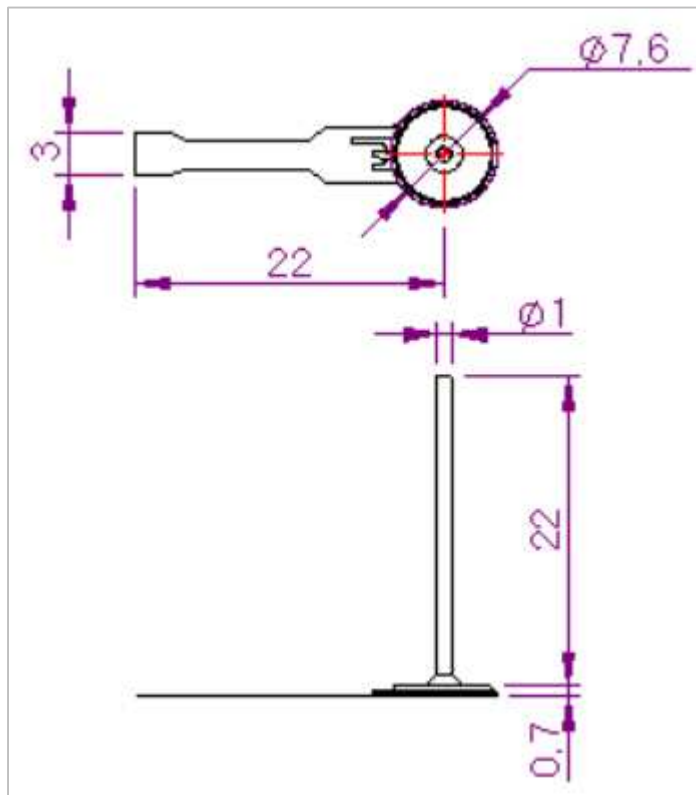

[Figure 3-1] PZM-70L-220

4. Application Information

4.1 Driving waveform

The PWM signals to the piezo motor determine the direction and speed of the mobile part (slider).

A. Forward direction

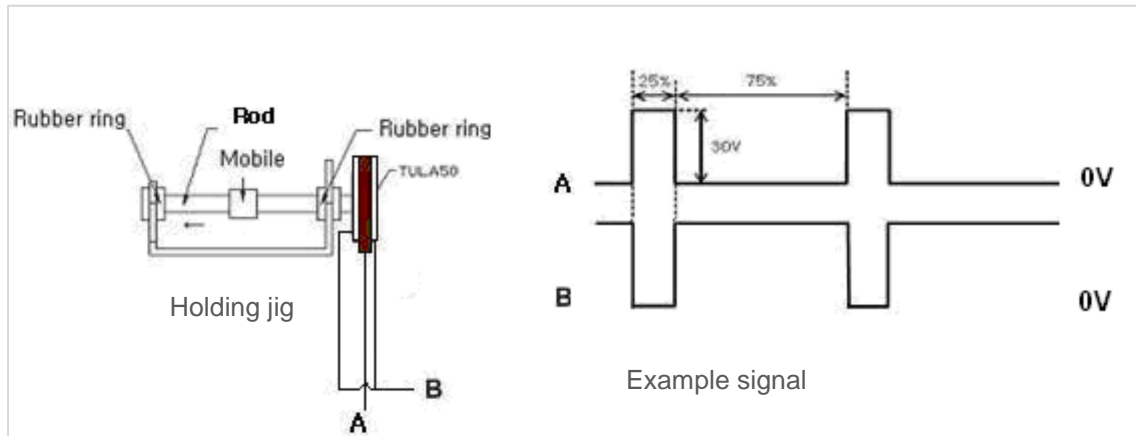

[Figure 4-1] Piezo Motors driving PWM signal

B. Reverse direction

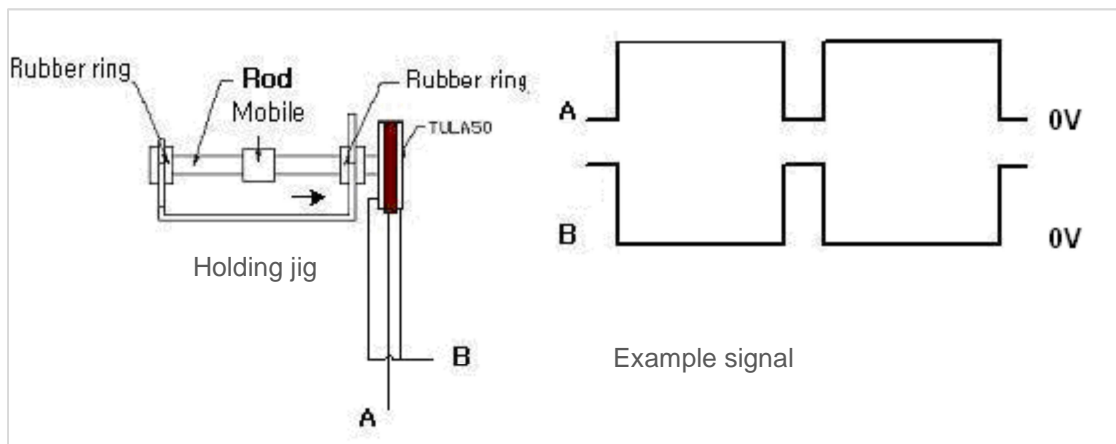

[Figure 4-2] Piezo Motors driving PWM signal

C. No operation

If the driving signals of piezo motor are in DC level or high impedance, the mobile part (slider) does not move and due to friction the slider stays at its position. In this case, piezo motor does not consume any power.

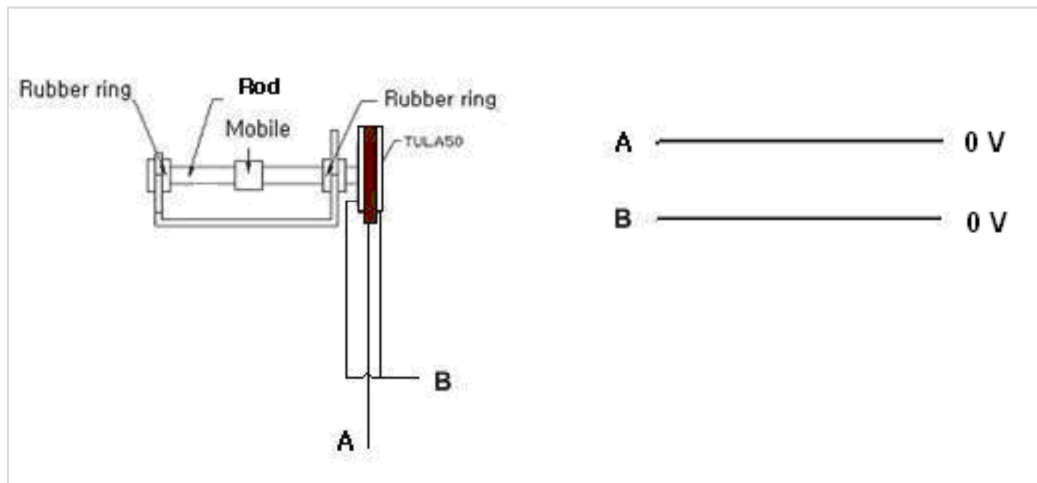

[Figure 4-3] No signal, no power consumption

4.2 Mechanical characteristics

In order to control the speed of piezo-motor, the duty or frequency is important factor. [Figure 4-4] shows the typical characteristics of speed and current according to the duty ratio at fixed driving frequency.

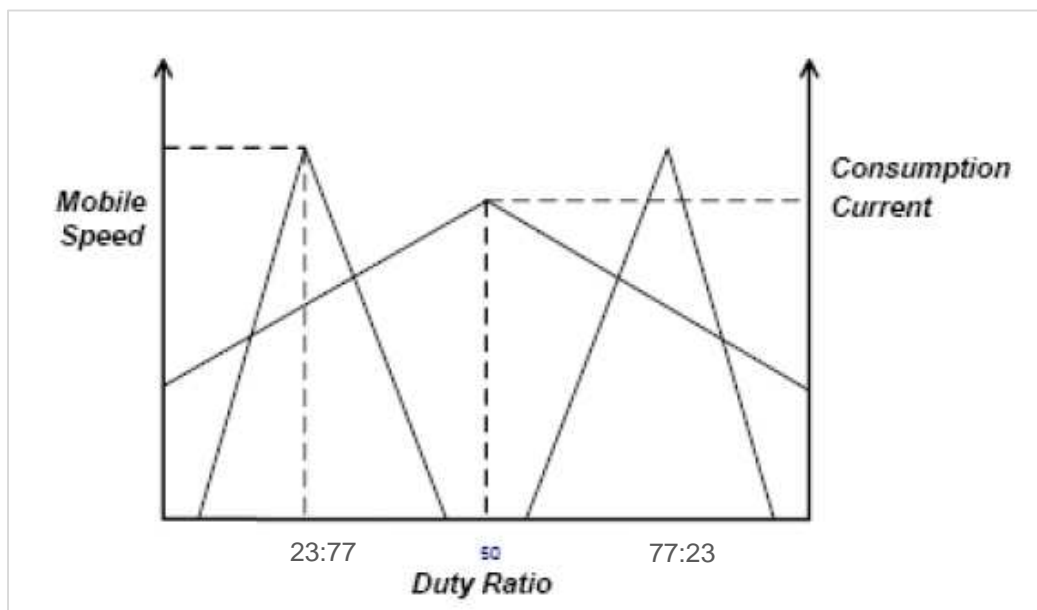

[Figure 4-4] Typical Duty vs Speed & Current, at fixed frequency

[Figure 4-5] shows the typical characteristics of the frequency versus speed. Depending on the ambient temperature, this graph will be shifted by several kHz

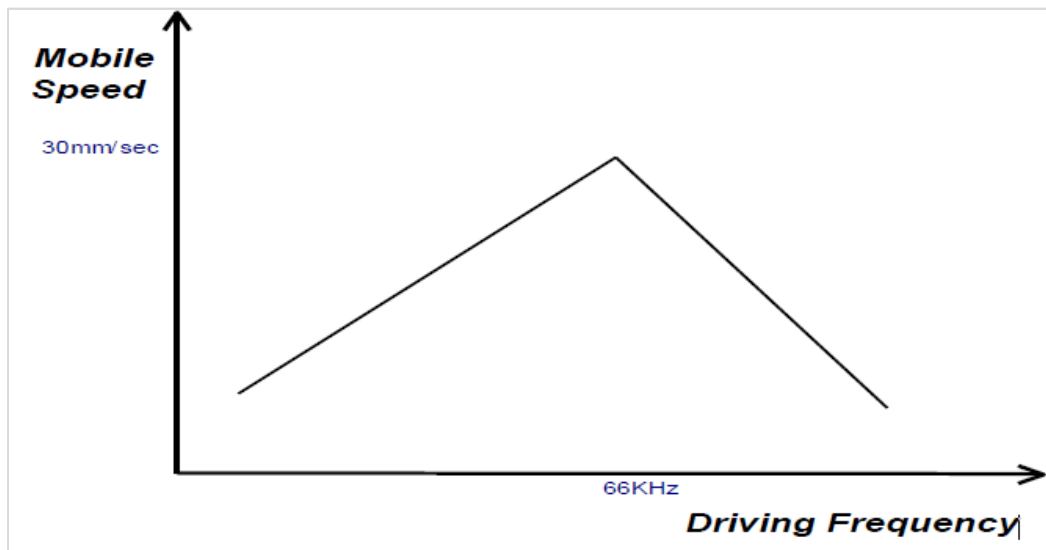

[Figure 4-5] General frequency characteristics

[Figure 4-6] shows the typical compressive force versus thrust and speed. In order to get more thrust, more compressive force to some extent is needed. Inversely, for a higher speed, a lower compressive force of mobile part (slider) is needed.

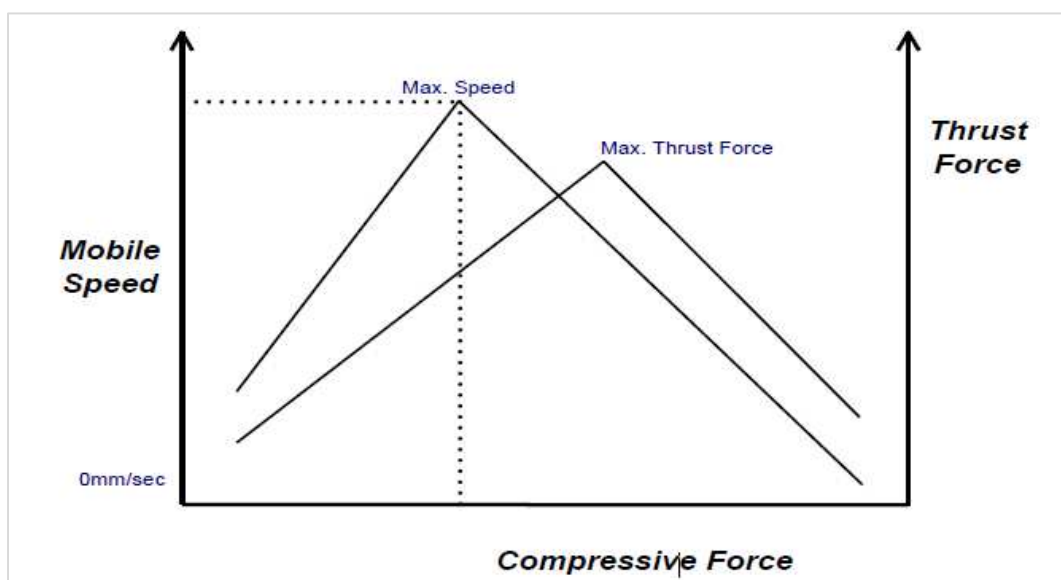

[Figure 4-6] Compressive force vs. speed & thrust

4.3 Position Sensors

A position sensor or encoder is needed for close-loop precision control. MR (Magnetic Resistive) sensors, hall sensors, PR (photo reflector) or encoders can be used to get the position of the mobile part (slider) according to user's application. **The accuracy and resolution depends on sensor or encoder used.**

4.4 Mobile part (slider) Examples

[Figure 4-7], [Figure 4-8] and [Figure 4-9] shows the good example of V-block, Plate-spring and mobile-body. This structure has high thrust and high holding force. Frictional surface length is 7mm.

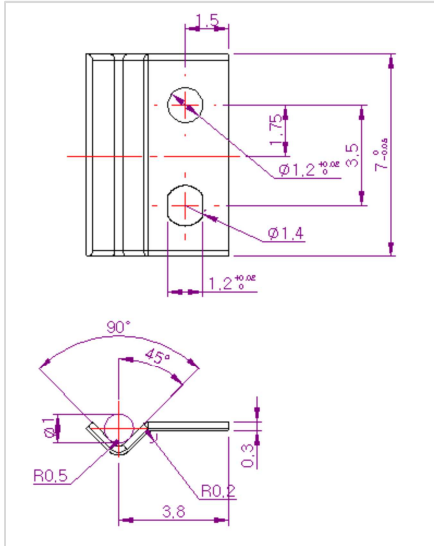

[Figure 4-7] V-block

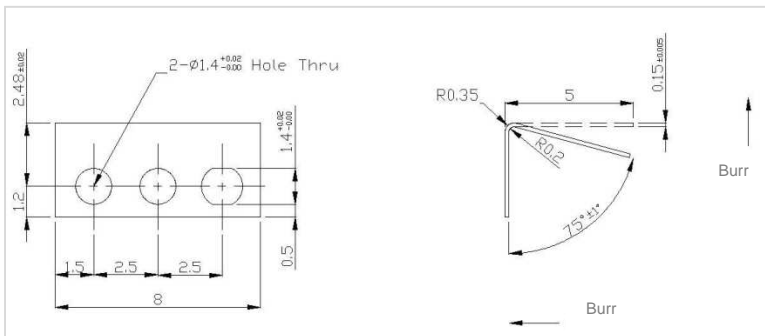

[Figure 4-8] Plate spring

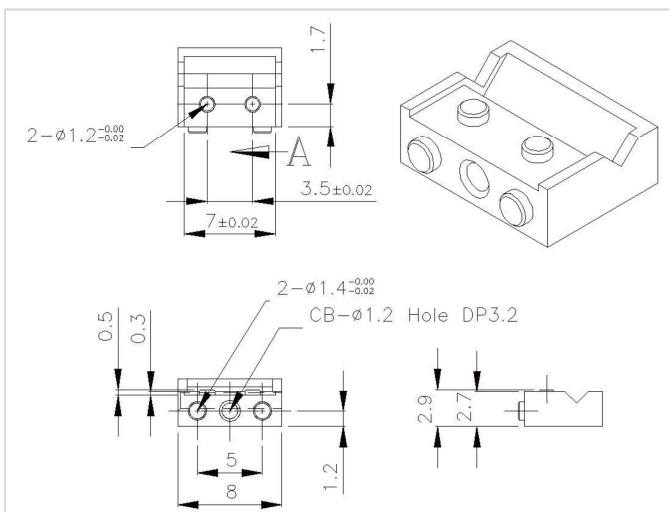

[Figure 4-9] Mobile-body

5. Driving Circuit

5.1 Single IC solution 1

LT3572 is 2 channel single chip solution for Piezo Motors. For more information, please refer to the technical data-sheet of LT3572.

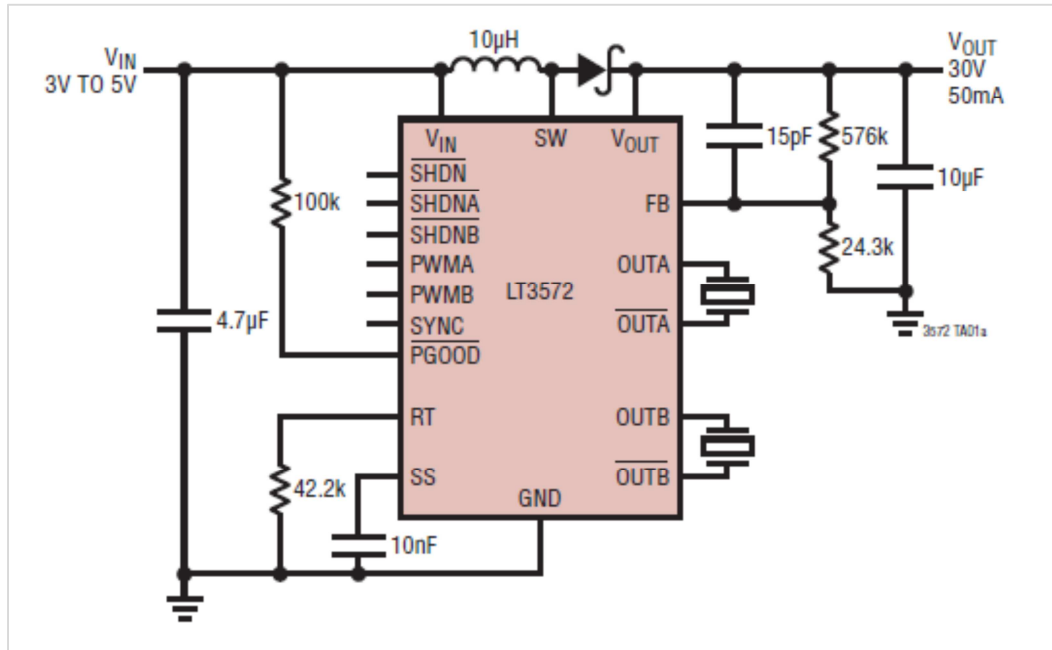

[Figure 5-1] LT3572 typical application

5.2 Single IC solution 2

NJW4813/4814 from “JRC” is single chip solution. NJW4814 is for 2 channels and NJW4813 is for single channel. For more information, please refer to the technical data-sheet of NJW4814 or NJW4813.

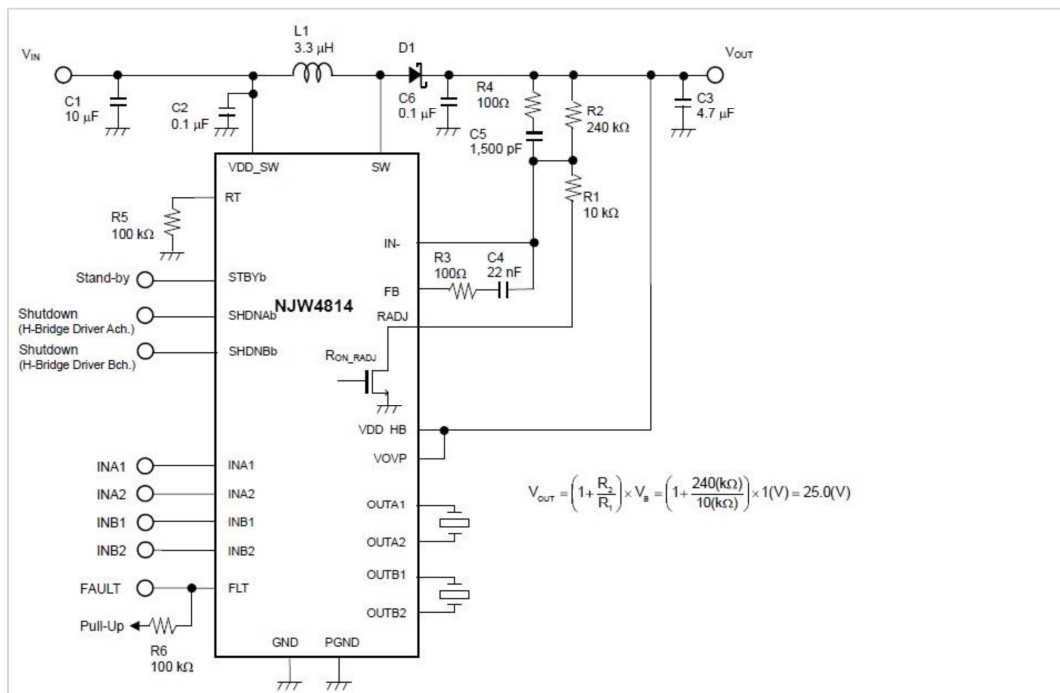

[Figure 5-2] NJW4814 typical application circuit



5.3 DC-DC Converter

In order to use the commercial half or full bridge FETs, a DC-DC converter (input 5V, output 20~35V) such as LT3467 (Linear Technology) is needed. The output voltage level can be adjusted by a feedback resistor. If you need more output-current, then LT1935 is a good alternative. L6226Q is a dual channel full-bridge FET. This driver IC can be used with DC-DC converter for driving Piezo Motors, in case that LT3572 or NJW4814/13 can't be used.



6. Evaluation Kit (PMC1202/ PMC1804)

To understand Piezo-motor-operation and develop user's application easily, PMC-1202 or PMC1804 are available. The driving frequency, voltage and duty ratio can be adjusted. For more information please refer to operation manual of PMC-1202 or PMC1804.

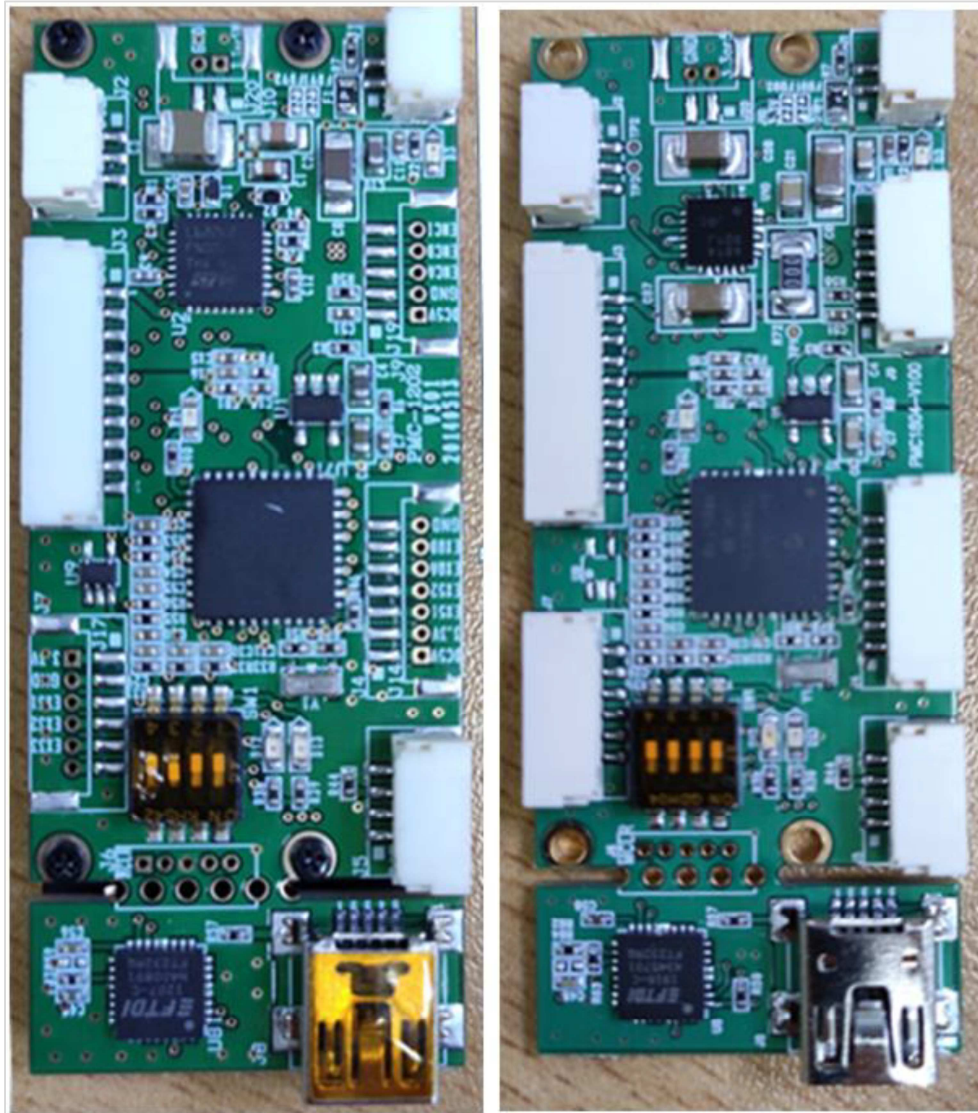

[Figure 6-1] PMC1202 / PMC1804

7. Reliability Test Result

Endurance characteristics

Approximately 80% of initial performances guaranteed after 500,000 cycles movement under following conditions:

- 2 mm stroke at the center of rod
- Max. Speed movement.

MTTF 6,300,000 cycles.

Piezo-Motor-Meter to test slider speed and current (ampere) is available from Piezolution GmbH.